

## Bursting Disc Plugs



Elfab bursting disc plugs have been specifically developed to provide a simple to install pressure relief solution.

This type of device is suitable for a wide range of applications, such as cryogenics, gas cylinders, autoclaves and portable compressed air systems.

The standard range offers various disc and holder combinations to produce an extensive range of burst pressures and connection options.

However, if your design specification falls outside the scope of the standard range, Elfab can design and develop custom engineered pressure relief solutions to meet your individual system requirements – see OEM.

- Wide range of burst pressures
- Gas and vapour compatible
- Various inlet & outlet combinations
- Simple installation
- Excellent leak integrity
- Tamperproof

Specifications	
THREAD SIZES	1/4" to 3/4"
THREAD TYPES	NPT or BSPT
BURST PRESSURE RANGE	2.5 to 200 barg (37 to 2900 psig)
TEMPERATURE RANGE	-40 to 400°C (-40 to 752°F)
MAXIMUM OPERATING RATIO	90% of min. burst pressure (2.5 – 55 barg) 85% of min. burst pressure (55 – 200 barg)
PERFORMANCE TOLERANCE	+/- 10% (2.5 – 55 barg) +/- 5% (55 – 200 barg)
LEAK INTREGRITY	brass 1x10 <sup>-5</sup> cc/sec, Stainless Steel 1x10 <sup>-7</sup> cc/sec
VACUUM SERVICE	yes
FLUID COMPATIBILITY	gas or vapour
TAMPERPROOF	yes
DISC TYPES	Uni-Gard (compression loaded) Conventional (tension loaded)
DISC MATERIAL	nickel or stainless steel
FRAGMENTATION	may fragment on burst
HOLDER DESIGN / MATERIAL	screwed/bonded brass with Viton® O-ring or electron beam welded stainless steel

## Connection, sizes and pressures

### Brass Plugs, Screwed and Bonded

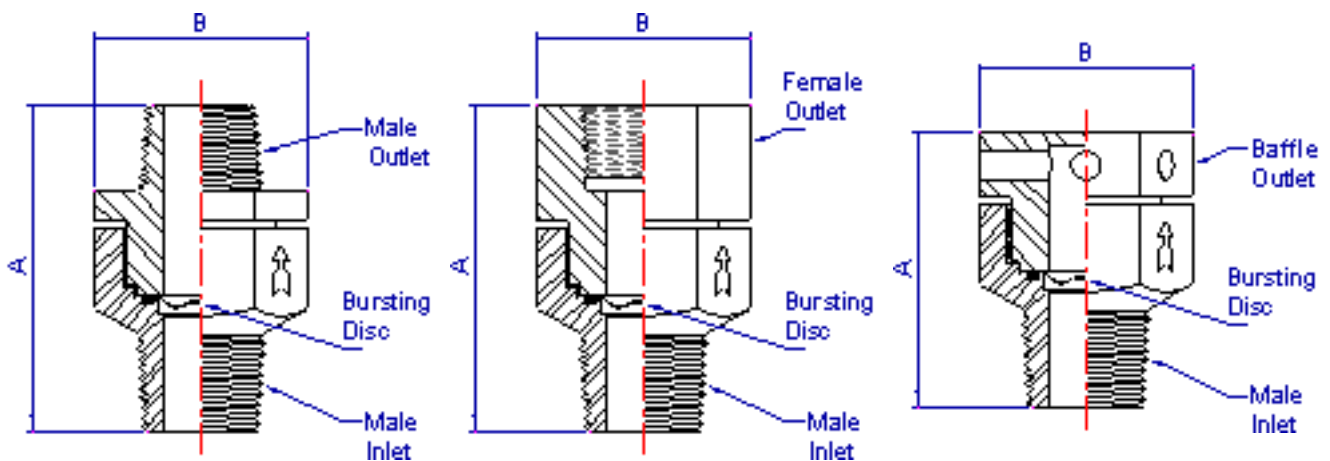

CONNECTIONS *		BURST PRESSURE RANGE @ 20° C		OVERALL LENGTH† ' A '	HEXAGON A/F. ' B '
Inlet	Outlet	Minimum	Maximum		
1/4" MALE	1/4" MALE	3 barg (44 ps ig)	70 barg (1015 ps ig)	57mm (2 1/4")	31.75mm (1 1/4")
	1/4" FEMALE			48mm (1 7/8")	
	BAFFLE				
1/2 MALE	1/2" MALE			57mm (2 1/4")	
	1/2" FEMALE			48mm (1 7/8")	
	BAFFLE				
3/4" MALE	3/4" MALE	2.5 barg (37 ps ig)	40 barg (580 ps ig)	68mm (2 11/16")	38.1 mm (1 1/2")
	3/4" FEMALE				
	BAFFLE			57 mm (2 1/4")	

\*Available in either NPT or BSPT thread

†For burst pressures above 55barg add 3mm (1/8") to overall length

### Stainless Steel Plugs, Electron Beam Welded

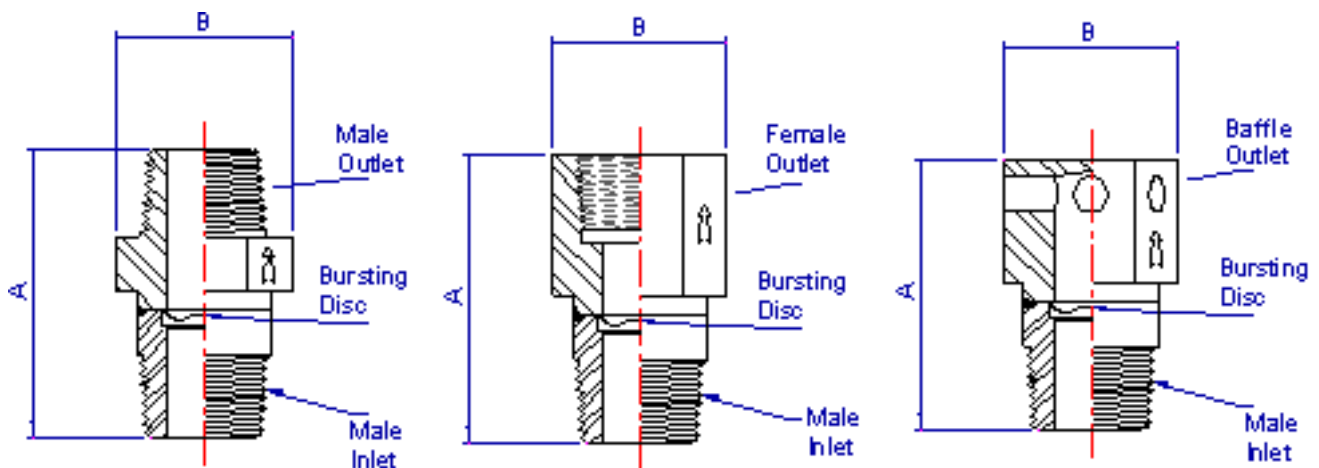

CONNECTIONS *		BURST PRESSURE RANGE @ 20° C		OVERALL LENGTH ' A '	HEXAGON A/F. ' B '
Inlet	Outlet	Minimum	Maximum		
1/4" MALE	1/4" MALE	3 barg (44 ps ig)	200 barg (2900 ps ig)	49mm (1 15/16")	31.75mm (1 1/4")
	1/4" FEMALE			46mm (1 13/16")	
	BAFFLE				
1/2" MALE	1/2" MALE			49mm (1 15/16")	
	1/2" FEMALE			46mm (1 13/16")	
	BAFFLE				
3/4" MALE	3/4" MALE	2.5 barg (37 ps ig)	40 barg (580 ps ig)	56mm (2 1/4")	31.75 mm (1 1/4")
	3/4" FEMALE				
	BAFFLE			53 mm (2 1/16")	

\*Available in either NPT or BSPT thread

## General specifications

### Body Material / Finish

Brass

Stainless Steel

General surface finish 1.6µmRa (0.8µmRa in critical areas). All burrs and sharp edges removed unless otherwise stated.

### Disc Material

Nickel

Stainless Steel

## Burst Pressure Range

Disc Type	Disc Material	Nominal Bore of Disc (thread sizes)	Burst Pressure Range @ 20° C				Tolerance	Maximum Operating Ratio
			Brass		Stainless Steel			
			Min	Max	Min	Max		
Uni-Gard (compression loaded)	Nickel	15mm (1/4", 1/2")	3 barg (44 psig)	55 barg (800 psig)	3 barg (44 psig)	55 barg (800 psig)	+/- 10%	90%
		19mm (3/4")	2.5 barg (37 psig)	40 barg (580 psig)	2.5 barg (37 psig)	40 barg (580 psig)		
	Stainless Steel	15mm (1/4", 1/2")	4 barg (58 psig)	55 barg (800 psig)	4 barg (58 psig)	55 barg (800 psig)		
		19mm (3/4")	4 barg (58 psig)	40 barg (580 psig)	4 barg (58 psig)	40 barg (580 psig)		
Conventional (tension loaded)	Nickel	15mm (1/4", 1/2")	55 barg (800 psig)	70 barg (1015 psig)	55 barg (800 psig)	200 barg (2900 psig)	+/- 5%	85%
		19mm (3/4")	N/A	N/A	N/A	N/A		
	Stainless Steel	15mm (1/4", 1/2")	55 barg (800 psig)	70 barg (1015 psig)	55 barg (800 psig)	200 barg (2900 psig)		
		19mm (3/4")	N/A	N/A	N/A	N/A		

## Temperature Range

Body Material	Temperature, °C (°F)			
	Standard		Alternative*	
	Min	Max	Min	Max
Brass	15 (59)	200 (392)	-20 (-4)	200 (392)
Stainless Steel	15 (59)	200 (392)	-40 (-40)	400 (752)

\*An additional charge is required due to extra temperature testing requirements

## Leak Tightness

### Brass Body

- Screwed and bonded with 'Loc-Tite 290 Threadlocker'
- Viton® O-ring used with temperature range -30 to 204°C (-20 to 400°F)
- Helium Leak tested and tight to  $1 \times 10^{-5}$  cc/sec

### Stainless Steel Body

- Electron Beam Welded to withstand maximum burst pressure of the disc +10%
- Helium Leak tested and tight to  $1 \times 10^{-7}$  cc/sec

## Free Flow Area (Minimum Net Flow Area)

Body Material	Thread Size	Free Flow Area (MNFA)					
		Male Outlet		Female Outlet		Baffle Outlet	
		mm <sup>2</sup>	inch <sup>2</sup>	mm <sup>2</sup>	inch <sup>2</sup>	mm <sup>2</sup>	inch <sup>2</sup>
Brass	1/4"	28	0.0438	28	0.0438	28	0.0438
	1/2"	127	0.1964	127	0.1964	118	0.1826
	3/4"	286	0.4441	286	0.4441	170	0.2630
Stainless Steel	1/4"	28	0.0438	28	0.0438	28	0.0438
	1/2"	127	0.1964	127	0.1964	127	0.1964
	3/4"	286	0.4441	286	0.4441	286	0.4441

## CE Marking

Conforms with the requirements of:

Annex III, Module H1 of the Pressure Equipment Directive 97/23/EC, and schedule 4 of the Pressure Regulations 1999

## Pressure Intelligence

The data shown on these sheets represents the standard offering from Elfab. Depending upon the requirements of your application, Elfab maybe able to provide a solution based on this product but outside the standard operating parameters. In addition, Elfab produces an extensive range of alternative products which maybe more suitable for your requirements.

As a result of extensive testing, Elfab can advise on these choices, or on other technical matters, such as discharge requirements, temperature testing, material selection and corrosion resistance, customised designs and burst detection.

**To discuss your specific product or service requirements please contact your Elfab representative.**



© 2004 Elfab Ltd.

